

THE IMPACT OF REGULAR LONG TERM PHYSICAL LOAD ON CARDIOVASCULAR FUNCTIONAL PARAMETERS IN CHILDREN AND ADOLESCENT ATHLETES

**Aldona Bartkevičienė¹, Dalia Bakšienė², Alfonsas Vainoras², Pranas Šerpytis³,
Geriuldas Žiliukas¹**

¹Klaipėda University, Lithuania, ²Lithuanian University of Health Sciences,

³Clinic of Heart and Vascular Medicine, Faculty of Medicine, Vilnius University

Key words: children, athletes, complexity, functional parameters.

Summary

Introduction. Regular physical load determines increase in functional capability of cardiovascular system. On the other hand, the cardiovascular system often appears as a conditional factor, which restricts organism adaptive abilities and limits general organism adaptation to the load. During physical load, not only cardiovascular system is activated, but also complex changes take place in the whole body. Therefore, with the aim to evaluate the functions of various systems, interrelation between them and systemic response of the body to physical load, a complex research on distinctive features of not only functional indices of the cardiovascular system, but also parameters reflecting interrelationship among functional systems of the body and speed of their changes is carried out. The goal of such complex research is the evaluation of adaptive and reserve capabilities of the athlete's body and individualization and optimization of physical load.

The aim of this study was to evaluate the speed of changes of parameters that characterize the functional condition of human organism of children and adolescents athletes and non-athletes controls.

Materials and methods. One hundred sixty seven male athletes aged 14.8 (SD1.6, range 12-17 years) participating in basketball, rowing and cycling and 168 healthy sedentary controls matched for age, sex and body surface area performed a graded exercise test (Mc. Master) on a cycle ergometer. 12 ECG standard derivations were synchronically recorded every second minute. During cycle ergometer inte-

grated functional parameters, which could integrally and simple evaluate organism reaction to physical load, were assessed.

Results. The present study demonstrates that before reaching the maximum of physical load, the speed of changes JT/RR in athletes and all functional parameters (HR, JT interval, RR interval, systolic blood pressure (SBP), diastolic blood pressure (DBP), pulse blood pressure (SBP-DBP), JT/RR ratio) in the control group decreased and in the last step of physical load has increased. That suggests that during intensive exercise training limits of physiological changes can be exceeded in athletes.

Conclusions. Analysis of speed of changes in functional parameters during physical load can be applied for the evaluation of functional state of the human body and the cardiovascular system and aiming to optimize and individualize physical load in athletic children and adolescents.

Introduction

Cardiovascular system plays a main role in the adaptation of human organism to long-term physical load (1, 2). Functional capacity of the cardiovascular system determines adaptive abilities of organism. On the other hand, functional possibilities of the cardiovascular system often become a factor limiting adaptive processes in the body (3). Therefore, it is of crucial importance to evaluate precisely adaptive changes of the cardiovascular system and assess the limit a functional possibilities of organism.

During long-term exercise training human organism undergoes complex interrelated structural and functional changes of many organ systems. Therefore, not only functional indices of the cardiovascular system, but also parameters reflecting interrelationship among functional

systems of the body is carried out (4, 5). From this point of view, the integral model of body's response to physical load, created by A. Vainoras, is very informative (4).

The aim of this study was to evaluate the speed of changes of parameters that characterize the functional systemic condition of human organism of children and adolescents athletes and non-athletes controls.

Materials and methods

One hundred sixty seven male athletes aged 14.8 (SD1.6, range 12-17 years) participating in basketball, rowing and cycling and 168 healthy sedentary controls matched for age, sex and body surface area performed a graded exercise test (Mc. Master) on a cycle ergometer. 12 ECG standard derivations were synchronically recorded every second minute (2). By using the model of integral response of the human body to physical load the following functional parameters and its speed of changes were estimated: heart rate (HR), JT interval, RR interval, systolic blood pressure (SBP), diastolic blood pressure (DBP), pulse blood pressure (SBP-DBP), JT/RR ratio (3, 5).

According the sporting discipline the athletes were divided into three groups as follows: basketball players (n=62), rowers (n=51) and cyclists (n=54). The most of athletes belonged to various regional teams, 5 (2.9%) athletes were members of the national team. The characteristics of the subjects are presented in Table 1.

None of the athletes had any cardiac systemic disea-

ses on the basis of negative medical history and physical examination, none of the athletes were receiving any medication, none had acute diseases acquired one month before the study and during it, and none had trauma experienced during the last 3 months before the study and during it. Training backgrounds for last 12 months were determined according to declarations made by the team coaches. The athletes were engaged in physical activity for last 12 months for an average of 8.1 (2.3) hours a week. Average training duration was 3.2 (2.2) years. The training duration of basketball players was longer than of rowers and cyclists ($P<0.05$) Rowers training volume was greater than basketball players ($P<0.05$).

Controls were 168 healthy pupils from Klaipeda secondary school of similar age, gender and body surface area as athletes. They were not participated in additional sports activities outside of physical education classes in school during the last years; their weekly physical activity was less 2 hours. Any cardiac or systemic pathology was ruled out by physical examination made by a general practice physician.

The participants completed cycle ergometer test on an Archimed ergometer by performing two-minute cycling bouts at incrementally ascending workloads to submaximal HR (85% of maximal heart rate) or symptom-limited maximum (6).

For bicycle ergometer testing, the McMaster protocol was used: if a subject was shorter than 160 cm, the initial

Table 1. Comparison of demographic, anthropometric and training parameters between athletes and controls

Characteristic	Athletes, n=167		Controls, n=168		P value
	Mean (SD)	95% CI	Mean (SD)	95% CI	
Age, years	14.8 (1.6)	14.6–15.1	14.6 (1.4)	14.6–15.0	0.923
Height, cm	175.9 (10.4)	174.3–177.5	174.3 (10.3)	172.7–175.8	0.103
Weight, kg	63.9 (13.5)	61.9–65.9	63.3 (15.6)	61.4–65.3	0.696
BSA, m ²	1.76 (0.23)	1.72–1.79	1.73 (0.19)	1.71–1.76	0.282
Training duration, years	3.2 (2.2)	2.9–3.6	–	–	–
Training volume, hours/week	8.1 (2.3)	2.6–2.9	<2	–	–

BSA – body surface area

Table 2. Comparison of heart rate and systolic arterial blood pressure at rest between athletes and controls

Parameter	Athletes, N=167		Controls, N=168		F; p
	Mean±SD	95 % CI	Mean±SD	95 % CI	
HR, (beats/·min)	76.17±12.12	74.28–78.05	82.00±9.09	79.97–85.05	14.18; < 0.001
SBP, (mmHg)	115.40±10.76	113.73–117.08	113.45±12.64	110.60–116.30	1.55; 0.215

HR – heart rate; SBP – systolic arterial blood pressure; SD – standart deviation; CI-confidence interval

workload of 25 W was applied further increasing it by 25 W every 2 minutes; if a subjects was taller than 160 cm, the initial workload of 25 W was applied further increasing it by 50 W every 2 minutes (2, 8). The pedaling frequency was maintained at 60 revolutions per minute throughout testing.

During cycle ergometer testing, at rest and during the last 10 s of every step of physical load, systolic blood pressure (SBP) and diastolic blood pressure (DBP) were measured using an aneroid manometer, and 12-lead ECG was recorded. Blood pressure (BP) at rest was measured three times every two minutes in the sitting position by auscultation of Korotkoff's sounds over the brachial artery using a stethoscope. In the evaluation of blood pressure, a mean value of three measurements was obtained. After measuring SBP, pulse pressure (SBP-DBP) was calculated at rest and during every step of physical load. During 12-lead echocardiography, heart rate (HR), JT interval (interval between J point and T wave) were measured at rest and during every step of physical load; RR interval and relative JT/RR index were calculated.

By using the model of integral response of the human body to physical load, both separate and integrated functions of the systems mentioned above were evaluated (4). During cycle ergometer testing, parameters reflecting several main interrelated systems of the human body – executive (ES), supplying (SS) and regulatory (RS) – were registered.

With the aim to evaluate the relationship among separate systems at rest and during every step of physical load, a relative index – JT/RR – was calculated.

Functional parameters SBP and HR are more associated with regulatory system, (SBP-DBP) is associated with function of peripheral muscles and describes the response of executive system; JT interval is related to cardiovascular system and describes supplying system and JT/RR reflects associations between regulatory and supplying systems.

While evaluating the changes in the selected parameters, their interrelationship and the total results of all changes have occurred; it was possible to characterize the adaptation of the human body to the load applied and to give recommendations for the optimum load to be assigned.

With the aim to evaluate a quantitative value of change in functional parameters (HR, JT, JT/RR, SBP, DBP, (SBP-DBP) during physical load, speed of changes in functional parameters was calculated every second minute, i.e. it was determined how much functional indices were increased for one watt of load every second minute of physical load.

Speed was calculated according to the formula:

$$f_i = (f(N_{i+2}) - f(N_i)) / (N_{i+2} - N_i),$$

where f_i indicates speed of changes in a functional parameter during physical load; f , numerical value of functional parameter; $i = 2, 4, 6, 8, 10$, the second, fourth, ..., minute of physical load, when load is increased every 2 min; $N = 0, 25, 50, 75, 100, 125, 150, 175$ W for study participants who were shorter than 160 cm and $N = 0, 25, 75, 125, 175, 225, 275$ W for study participants who were taller than 160 cm.

Speed of changes in parameters was defined as follows:

JT2 – speed of changes in JT parameter from 0 W to 25 W for all the study participants.

JT4 – speed of changes in JT parameter from 25 W to 50 W for the study participants who were shorter than 160 cm and from 25 W to 75 W for the study participants who were taller than 160 cm at the fourth minute of workload.

JT6 – speed of changes in JT parameter from 50 W to 75 W for the study participants who were shorter than 160 cm and from 75 W to 125 W for the study participants who were taller than 160 cm at the sixth minute of workload.

JT8 – speed of changes in JT parameter from 75 W to 100 W for the study participants who were shorter than 160 cm and from 125 W to 175 W for the study participants who were taller than 160 cm at the eighth minute of workload.

JT10 – speed of changes in JT parameter from 175 W to 225 W for the study participants who were taller than 160 cm at the 10th minute of workload.

Indications of speeds of changes for other parameters – HR, JT/RR, SBP, (SBP-DBP) – were analogous.

All statistical analyses were performed using SPSS for Windows 15.0 software. Standard statistical parameters were applied for the descriptive analysis: for continuous data – arithmetic mean, 95% confidence interval (CI), standard deviation, for nominal data – distribution proportions (95% CI). For testing statistical hypotheses, parametric tests (paired or unpaired t test, ANOVA) were used with the assumption that the data being tested were normally distributed.

Results

HR at rest was lower in athletes than in subjects from the control group; meanwhile there was no difference in SBP between athletes and controls (Table 2).

During the maximal physical load, systolic blood pressure was higher in athletes than in controls. Higher SBP was documented in basketball players, rowers and cyclists as compared to the control group, and SBP in rowers was higher than an analogous parameter in cyclists and basketball players (Figure1).

With the aim to evaluate more precisely the adaptation of the body to long-term physical load, speeds of changes in functional parameters (HR, JT interval, JT/RR, SBP,

Figure 1. Systolic blood pressure (SBP) during maximal load within each sporting discipline for 167 athletes and 168 controls

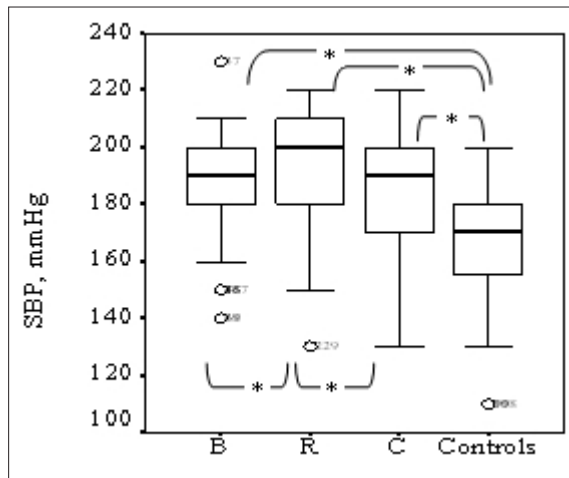

Notes: B, basketball players; R, rowers; C, cyclists; Central lines indicates median, lower and upper box borders the 25th and 75th, and extension borders the 10th and 90th distribution percentiles; *p<0.05

Figure 2. Comparison of speed of changes in heart rate (HR) between athletes and controls during physical load

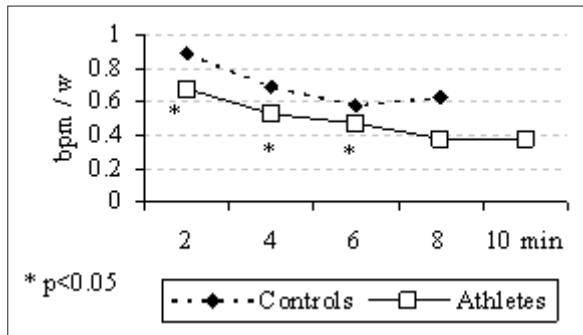

(SBP-DBP)) were derived during physical load, i.e. it was determined how much functional indices were increased for one watt of load every second minute of physical load.

The speed of changes in HR of athletes was decreasing equally and was significantly lower during the physical load, except sixth and eighth minute, than that of controls. The dynamics of speed of changes in HR of controls was peculiar: from the second to the sixth minute it was decreasing and in the last step of physical load has increased (Figure 2).

The speed of changes in JT interval of athletes was decreasing equally during the physical load. Meanwhile, speed of changes in JT interval of controls to the fourth minute was decreasing gradually, from the fourth to the sixth

Figure 3. Comparison of speed of changes in JT interval between athletes and controls during physical load

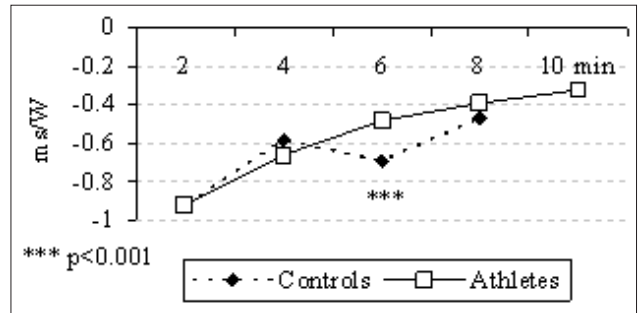

Figure 4. Comparison of speed of changes in JT/HR ratio between athletes and controls during physical load

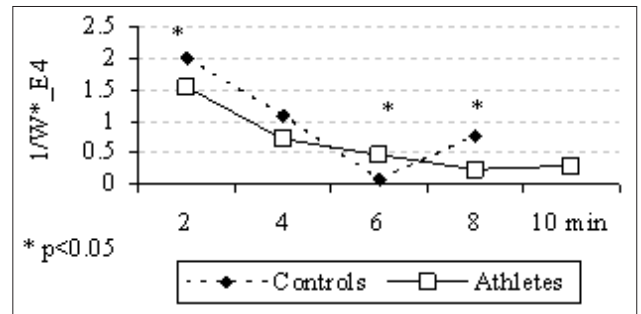
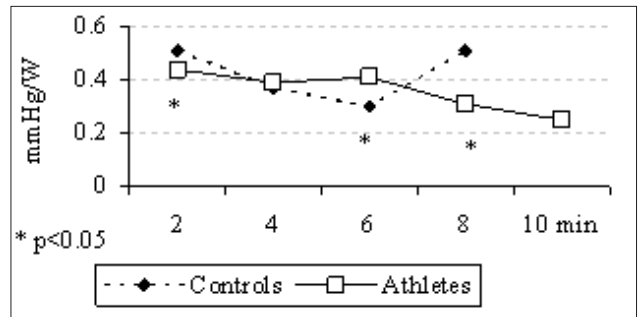

Figure 5. Comparison of speed of changes of systolic blood pressure (SBP) between athletes and controls during physical load



minute increased, and from the sixth to the eighth minute was decreasing again. There was a significant difference in the speed of changes in JT interval between athletes and controls only in the sixth minute of the load (p<0,001) (Figure 3).

The speed of changes in the JT/RR ratio, that indicate the connection between the regulatory and supplying systems during load, has been evaluated. The speed of changes in JT/RR ratio in athletes, before reaching the maximum of physical load, was the lowest and in the eighth minute – the last step of physical load has increased. In the control

subjects, like athletes, the speed of changes in JT/RR ratio before reaching the maximum of physical load, decreased and in the last step of physical load has increased. However the controls have reached the lowest the speed of changes in JT/RR ratio earlier compared to athletes. The significant difference in the speed of changes in JT/RR ratio between athletes and controls have been observed in the second, sixth and eighth minute of the load ($p < 0,001$) (Figure 4).

There was a slight alternation of speed of changes in SBP of athletes from second to sixth minute of the load. From sixth to tenth minute the speed of changes in SBP was decreasing and has reached the lowest value in the tenth minute. The dynamic of speed of changes in SBP of controls was differently. From the beginning to sixth minute of the load the speed of changes in SBP was decreasing equally and in the last step of physical load has increased. There were significant differences in speed of changes in SBP between athletes and controls at the second, sixth and eight minutes of the load ($p < 0,001$) (Figure 5).

The alteration of the speed of changes in pulse pressure (SBP–DBP) was similar.

During the physical load, speed of changes in all functional indices of athletes was decreasing equally, except for speed of changes in SBP and (SBP–DBP), which from the second minute to the sixth minute remained almost the same and from the sixth minute started to decrease. There were significant differences in speed of changes in HR, JT interval, JT/RR, SBP and (SBP–DBP) between athletes and controls during the load: in athletes, speed of changes in HR was lower at the second, fourth and sixth minute, speed of changes in SBP, (SBP–DBP) and JT/RR ratio was lower at the second and eight minutes of physical load than analogous ones in the control group. A significant difference in speed of changes in JT between athletes and control subjects was shown only at the sixth minute of physical load.

Speed of changes in JT/RR in athletes, before reaching the maximum of physical load, decreased and in the last step of physical load has increased. In the control subjects the speed of changes in nearly all functional indices (HR, JT/RR, SBP, SBP–DBP), before reaching the maximum of physical load, was the lowest and in the last step of physical load has increased except for the speed of changes in JT, which decreased earlier at the fourth minute, from the fourth to sixth minute increased and from the sixth to eight minute again decreased.

Discussion

Regular physical training in athletes causes adaptive structural and functional changes within the heart. During physical load, not only cardiovascular system is activated,

but also complex changes take place in the whole body (4, 5, 9). However, both in Lithuanian and worldwide literature, there is a paucity of scientific studies examining functional state of the cardiovascular system and systemic response of the body to physical load in athletic children and adolescents.

An obvious indicator of cardiovascular adaptation to regular aerobic training is a lowering of HR at rest and during submaximal exercise (2, 10, 11). The changes in HR are primarily due to alterations in autonomic tone: parasympathetic tone slows down the HR, and sympathetic stimulation increases it.

The results of study showed that the resting heart rate of athletes was slower compared to sedentary controls. Cardiac adaptation to intensive training in athletes includes vagal predominance. The lowering of resting HR is mediated by alterations in the autonomic nervous system and by changes in the intrinsic mechanism of the sinus node and right atrial myocytes (7). It could indicate the better adaptation of regulatory system and whole organism to long-term physical training (2, 3, 13).

Human functional possibilities closely linked with the changes of the arterial blood pressure (7). There is a lack of data regarding impact of long-term exercise training to systolic blood pressure in children athletes (7, 11). Jian Rong Shi reported the effects of endurance training in SBP of adolescent athletes. No differences in SBP were observed, comparing athletes to sedentary controls (7). Our results confirmed that: SBP in rest did not differ among athletes and controls. The athletes were involved in physical activity during last years for an average of 8.1 hours a week. Whereas the studies showed that only moderate-intensity exercise may lower blood pressure in adults (13, 15). However, systolic blood pressure during the maximum of physical load of athletes was greater compared to controls. An elevated SBP response to exercise has been also observed in endurance- and strength-trained athletes and it seems to be positively associated with exercise capacity (16). We suggest that higher SBP of athletes during the maximum of physical load could be reflected to sporting discipline. In our study SBP in rowers was higher than in cyclists and basketball players. Rowing includes the components of endurance and resistance training, but there is an upper and lower body imbalance that could influence to systolic blood pressure (16, 17). On the other hand, this study cannot reject the possibility genetic predisposition to higher blood pressure during exercise (18, 19).

Regular aerobic training is associated not only with changes of separate functional parameters of cardiovascular system but also involve such parameters that indicate

the interrelationship of the various systems of the human body.

With the aim to evaluate more precisely the adaptation of the body to long-term physical load we used the model of integral response of the human body to physical load (4, 12, 13). We evaluated the speed of changes of functional parameters, that indicate complex adaptation of human organism to physical load.

Results showed that not only resting heart rate but the speed of changes in heart rate of athletes was lower compared to controls. It associated to better adaptation of regulatory system to physical load. These results are similar to results of study involving adult athletes (13).

JT interval in ECG is closely associated to myocardial repolarisation and indicates myocardial metabolic processes (4). The changes in JT interval is related with intensity of myocardial metabolism. Our results showed that the speed of changes in this parameter was lower in athletes, however dynamic was more consistent compared to controls. The lower speed in changes of JT interval indicates a better adaptation of supplying system of athletes to load. In studies involving adult athletes, Zumbakyte and colleagues confirmed the existence the differences in the changes in speed of JT interval between athletes and controls (13).

During the lasts minutes of the physical load we can indentify the limits of functional possibilities of human organism and process of mobilization of reserves (4, 13). With assessing not only single, but complex systems of the human organism during physical load, scientists suggested the evaluation the parameters that indicate the interrelationship between systems (4, 13). The one of it – the relative parameter JT/RR, define the connection between the regulatory and supplying systems and mobilization of functional reserves of human organism during the load (13). Our findings showed that the speed of changes in JT/RR in athletes, before reaching the maximum of physical load, was the lowest and in the last step of physical load have increased. The lowest speed of changes in JT/RR of controls was recorded earlier at the sixth minute compared to athletes. It suggests the better adaptation of athlete's organism to physical load. During the load, the supplying and regulatory systems of athletes have been involved to the physical training longer and more constantly. On the other hand, an increase in speed of changes in JT/RR ratio in the last step of the load can indicate the limit of functional capacity of cardiovascular system and whole organism as well. We suggest that the alternation of the speed of this index might be regarded as indicating the point at which the load should be restricted. Our results agree with reports

indicating that dynamic of speed of changes in JT/RR ratio could identify the threshold functional capabilities, exceeding which deadaptive phenomena might occur in adult athletes (13).

Many studies showed that during dynamic exercise, children compensate a lower stroke volume by an increasing heart rate, thus, they attain higher heart rate than adults (1, 2, 10, 20, 21). However, dynamic of systolic blood pressure during physical load in children adolescent athletes is more consistent than in adults (1, 2, 11). Our results confirmed it. The speed of changes in systolic blood pressure of athletes to the sixth minute remained almost the same and from the sixth minute started to decrease. It could be explained by the fact, that, while body growth until the mechanism of blood flow is not developed, the main importance to increase in heart capacity during the load goes to heart rate. In adolescents and adults, after changes in blood-vessels appear, dominant alternations during load are determined by changes in systolic arterial blood pressure (2).

Conclusions

The present study demonstrates the better adaptation of cardiovascular system and whole body of athletes to physical load. On the other hand, the study results suggest the existing limits of functional capacity of human organism, especially during prepubertal and pubertal periods. The study results showed, that before reaching the maximal physical load, speed of changes in JT/RR in athletes and all functional parameters in the control group was the lowest and during the last step of the load increased that suggest that during intensive exercise training limits of physiological changes can be exceeded. Analysis of speed of changes in functional parameters during physical load can be applied for the evaluation of functional state of the human body and the cardiovascular system and aiming to optimize and individualize physical load in athletic children and adolescents.

References

1. Armstrong N, Welsman J. Physiology of the child athlete. *Lancet* 2005;366(1):44-5.
2. Bar-Or O, Rowland TW. Pediatric Exercise Medicine: From Physiologic Principles to Health Care Applications. Champaign, IL: Human Kinetics; 2004.
3. Ivaniura IO. The effect of prolonged physical loads on the cardiovascular system of middle-school-aged pupils. *Fiziol Zh* 1999;45(6):67-74.
4. Vainoras A. Functional model of human organism reaction to load – evaluation of sportsman training effect. *Education, Physical training, Sport*. 2002;88-93.

5. Torrents C, Balague N. Dynamic Systems Theory and Sports Training. *Ugdymas. Kūno kultūra. Sportas* 2006; 1(60):72–83.
6. Gibbons RJ, Balady GJ, Beasley JW, Bricker JT, Duvernoy WFC, Froelicher VF, et al. Guidelines for Exercise Testing: Executive Summary. *Circulation* 1997;96:345-354.
7. Jian Rong Shi. Cardiac structure and function in young athletes. [dissertation]. Department of Human Movement, Recreation and Performance, Victoria University of Technology; 2002.
8. Washington RL, Bricker JT, Alpert BS, Daniels SR, Deckelbaum RJ, Fisher EA, et al. Guidelines for exercise testing in the pediatric age group. From the Committee on Atherosclerosis and Hypertension in Children, Council on Cardiovascular Disease in the Young, the American Heart Association *Circulation* 1994;(90):2166-79.
9. Biggiero L. Sources of complexity in human systems. *J Nonlinear Dynamics. Psychology and Life Sciences* 2001;5(1):3-19.
10. Arts FJP, Kuipers H. The relation between power output, oxygen uptake and heart rate in male athletes. *International Journal of Sports Medicine* 1994;15:228-231.
11. Braden DS, Carroll JF. Normative cardiovascular responses to exercise in children. *Pediatr Cardiol* 1999;20:4-10.
12. Griniene E, Kačiulytė Z, Zumbakytė R, Vainoras A. Functional and mental working abilities for female after physical load. *Medicina (Kaunas)* 2005; 41(9).
13. Zumbakytė R. Krėpšinių ir futbolininkų funkcinės būklės ypatybės naudojant integraliojo vertinimo modelį (Assessment of functional conditions peculiarities of basketball and football players applying the model of integrated evaluation.) Dissertation. Kaunas: KMU; 2007.
14. Malcolm DD, Burns TL, Mahoney LT, Lauer RM. Left ventricular mass and exercise responses predict future blood pressure. *The Muscatine Study Pediatrics* 1993;92(5):703-9.
15. Cubero GI, Batalla A, Reguero JJR, Barriales R, Gonzales V, De la Iglesia JL, et al. Left ventricular mass index and sports: the influence of different sports activities and arterial blood pressure. *International Journal of Cardiology* 2000;75:261-5.
16. Focht BC, Koltyn KF. Influence of resistance exercise of different intensities on state anxiety and blood pressure. *Med Sci Sports Exerc* 1999;31:456-63.
17. Gates PE, George KP, Campbell IG. Concentric adaptation of the left ventricle in response to upper body exercise training. *Journal of Applied Physiology* 2003;94:549-554.
18. Chen W, Li S, Sirinivasan SR, Boerwinkle E, Berenson GS. Autosomal genome scan for loci linked to blood pressure levels and trends since childhood: the Bogalusa Heart Study. *Hypertension* 2005;45(5):954–59.
19. Crews DE, Harper GJ. Renin ANP, ACE polymorphism, blood pressure and age in American Samoans: preliminary data. *Am J Hum Biol* 1998;10:439–449.
20. Bale P. The Functional Performance of Children in Relation to Growth, Maturation and Exercise. *Sports Medicine* 1992;13(3):151-9.
21. Becker, Mônica de Moraes Chaves; Silva, Odwaldo Barbosa e; Moreira, Isaura Elaine Gonçalves; Victor, Edgar Guimarães. Arterial blood pressure in adolescents during exercise stress testing. *Arq Bras Cardiol* 2007; 88(3):329-333.

**FIZINIO KRŪVIO POVEIKIS SPORTUOJANČIŲ
VAIKŲ IR PAAUGLIŲ ŠIRDIES IR KRAUJAGYSLIŲ
SISTEMOS FUNKCINIAMS RODIKLIAMS**

**A. Bartkevičienė, D. Bakšienė, A. Vainoras, P. Šerpytis,
G. Žiliukas**

Raktažodžiai: vaikai, sportas, funkciniai rodikliai, kompleksiskumas.

Santrauka

Per paskutines fizinio krūvio mėginio pakopas galima nustatyti sportininkų širdies raumens darbingumo ribą ir kompensacinių mechanizmų įsitraukimo procesus. Šio tyrimo tikslas — naudojantis žmogaus organizmo funkcinės būklės įvertinimo modeliu, išnagrinėti 12–17 metų sportininkų organizmo funkcinis rodiklis bei jų kitimo greitį ir palyginti su kontrolinės grupės tiriamųjų atitinkamais rodikliais.

Tiriamąją grupę sudarė 12 – 17 metų 167 sportininkai ir 168 to paties amžiaus, lyties ir kūno paviršiaus ploto sveiki nesportuojantieji. Visiems tiriamiesiems atliktas veloergometrinis mėginys, taikant nepertraukiamą, kas dvi minutes pakopomis sunkėjantį fizinį krūvį iki submaksimalaus ŠSD arba krūvį ribojančių simptomų. Tirti šie rodikliai ir jų kitimo greitis: širdies susitraukimo dažnis (ŠSD), R-R intervalas (RR), J-T intervalas (JT), sistolinis arterinis kraujospūdis (SAKS), diastolinis arterinis kraujospūdis (DAKS), pulsinis kraujospūdis (SAKS-DAKS) ir išvestinis dydis - santykinė repoliarizacija JT / RR.

Sportininkų širdies susitraukimo dažnis ramybės metu bei širdies ir kraujagyslių sistemos funkcinių rodiklių (ŠSD, SAKS, JT intervalo, JT/RR, (SAKS–DAKS) kitimo greitis fizinio krūvio mėginio metu buvo mažesni už kontrolinės grupės tiriamųjų. Prieš pasiekiant fizinio krūvio maksimumą sportininkų JT/RR, o kontrolinės grupės visų funkcinių rodiklių (ŠSD, SASK, JT, JT/RR, (SASK–DASK) kitimo greitis buvo mažiausias, o paskutinėje fizinio krūvio mėginio pakopoje – padidėjo. Tai leidžia daryti prielaidą, kad sportininkams fizinio krūvio metu gali būti pasiekama ir net viršijama širdies ir kraujagyslių sistemos bei viso organizmo funkcinių galimybių riba.

Funkcinių rodiklių kitimo greičio analizė gali būti taikoma, vertinant sportuojančių vaikų ir paauglių širdies ir kraujagyslių sistemos ir viso organizmo funkcinę būklę bei fiziologinių pokyčių ribas ir siekiant optimizuoti bei individualizuoti fizinį krūvį.

Adresas susirašinėti: aldonabar@yahoo.com

Gauta 2012-11-26